

Melcourt Play Range - Recommended Installation Procedure

- Melcourt's range of loose impact absorbing surfaces (LIAS) will only perform to their full potential when correctly installed and maintained.
- By following the simple instructions below, which are provided for your guidance only, your Melcourt product will give a long service life.
- Two basic installation options are available:

'Above Ground Level' Pit

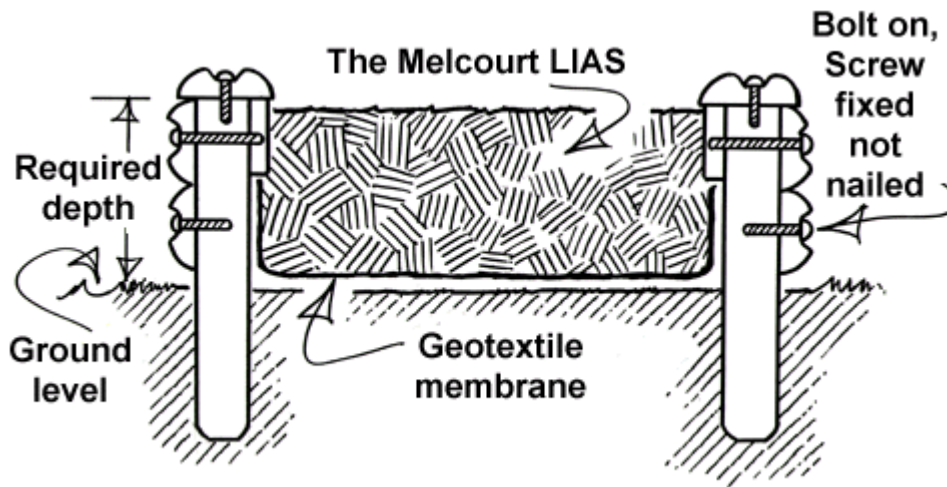

'Below Ground Level' Pit

End elevation for free draining site

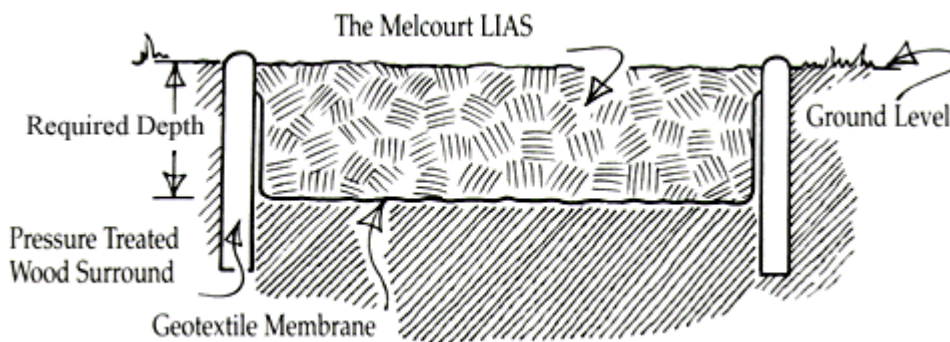

Continued

Melcourt Play Range - Recommended Installation Procedure (Continued)

'Below Ground Level' Pit

End elevation for poor draining site

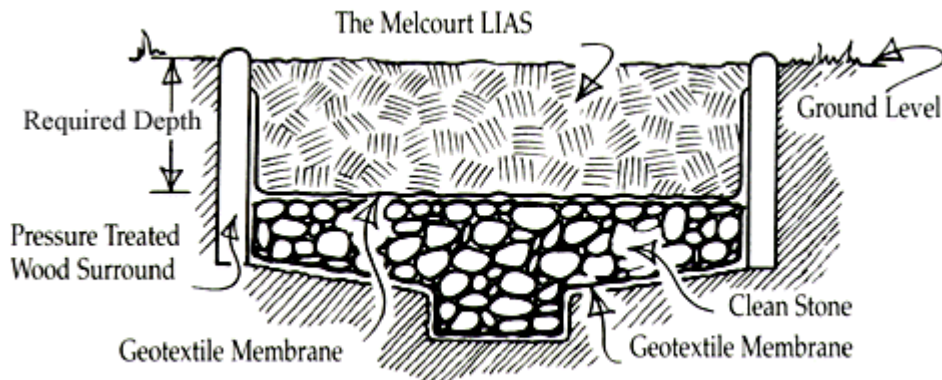

Key Construction Considerations

'Above Ground Level' Pit

- Cheapest installation option with no excavation or when possibility of localised flooding or a high water table prevents successful drainage.
- Easy installation requiring less use of heavy equipment causing ground damage.
- Most popular technique now used in approximately 70% of installations.

'Below Ground Level' Pit

- Can the soil or rock be successfully excavated?
- Can adequate "fall" be achieved for the drainage sump to function properly?
- Will the local topography cause flooding, preventing successful all-year drainage?

Design Access for Disabled People

- To comply with sections of the Disability Discrimination Act 1995, that came into effect on 1st October 1999, particularly on playgrounds where LIAS is used, the play provider will have carefully assessed and provides practical solutions, that allow the less-abled user to access the playground and traverse the surface to reach the play equipment.
- To comply with sections of the Disability Discrimination Act 1995, particularly on playgrounds where LIAS is used, the play provider must carefully assess and provides practical solutions that allow the less-able user to access the playground and traverse the surface to reach the play equipment.

Installation Procedure

- Decide which Melcourt product is to be used.
- Calculate the quantity of material required.
- To comply with BS EN 1176 the LIAS used must be installed to a layer thickness of 100mm more than that found by laboratory testing to be necessary to achieve the required critical fall height.
- When ordering, account should be taken of the settlement and provision should be made for a volume to be added as a top-up each year. Well used sites will require more than less used ones, particularly those installed with 'Playchips@', 'Kushyfall@' or 'Softfall' LIAS surfaces. Some lightly used sites will require little or no topping-up for several years.
- Decide which LIAS retention system is to be used, i.e. above or below ground level and order appropriate materials.
- Depending upon soil conditions a geotextile membrane will not always be necessary.
- Construct the LIAS retention system together with fencing and play equipment, in accordance with BS EN 1176 and fill with appropriate Melcourt LIAS.
- Reference to the API (Association of Play Industries) guide to the Provision of Rubber and Loose Impact Absorbing Surfaces, would also be useful.
- Where timber components are used they should be treated to comply with BS EN 351/1
- The equipment should now be independently tested and inspected before handover for use.

Melcourt Play Range - Recommended Installation Procedure (Continued)

For installations with moving equipment.

LIAS surfaces are not particularly well suited as an impact absorbing surface for areas immediately under or adjacent to moving equipment such as swings, roundabouts or around the exit points of slides. If synthetic surfaces are not acceptable at such locations, the depth of the chosen LIAS should be increased.

For some items such as cable runways, LIAS may be more suitable than rubber surfaces.

We recommend the following LIAS/rubber tile combinations in these situations:

Rubber Tiles installed as an anti-erosion surface under swings

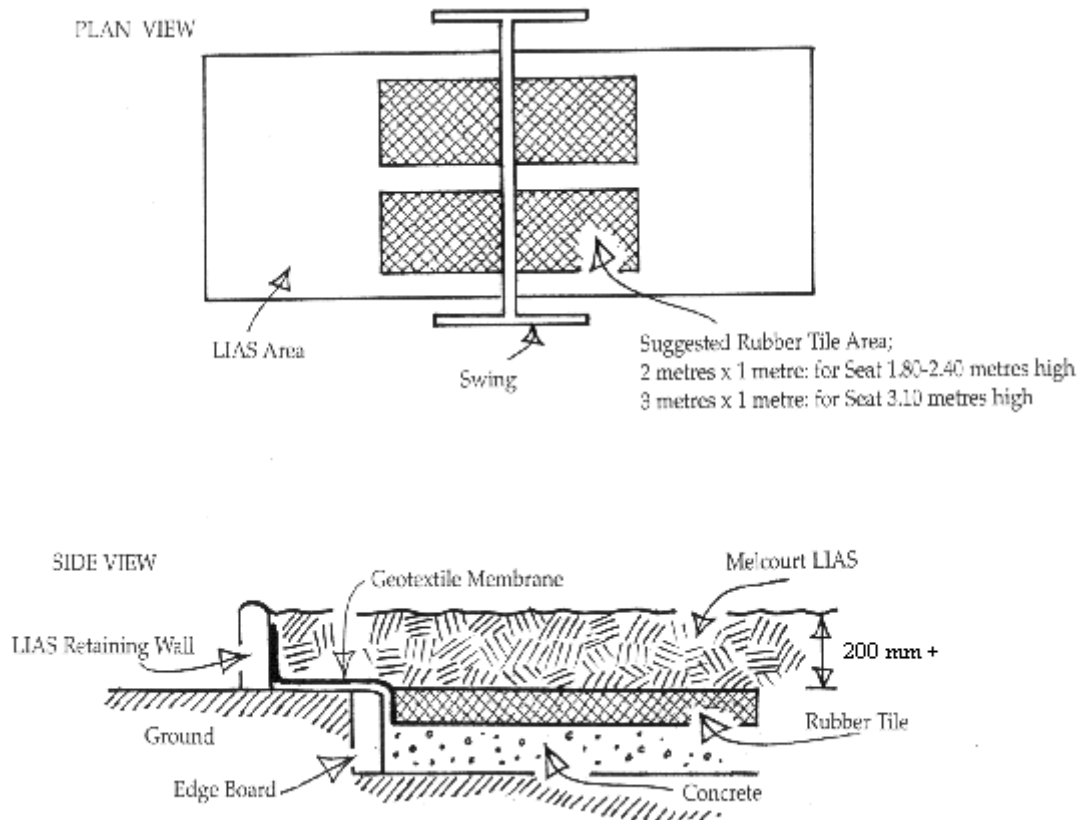

Note:

If the edge detail of the rubber tile is exposed, this will fail to comply with BS EN1176, due to there being a hard edge surface in the free fall space.

Therefore, the tiles should always be covered with LIAS, as shown.

We recommend that the seat be set 500 mm above the correct LIAS level

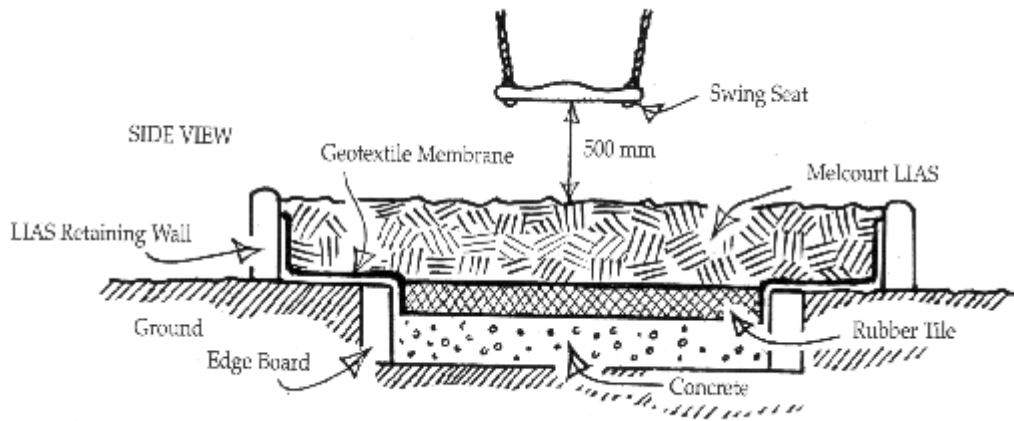

Continued

Malcourt Play Range - Recommended Installation Procedure (Continued)

Rubber Tiles or wet pour installed as an anti-erosion surface under/around roundabouts.

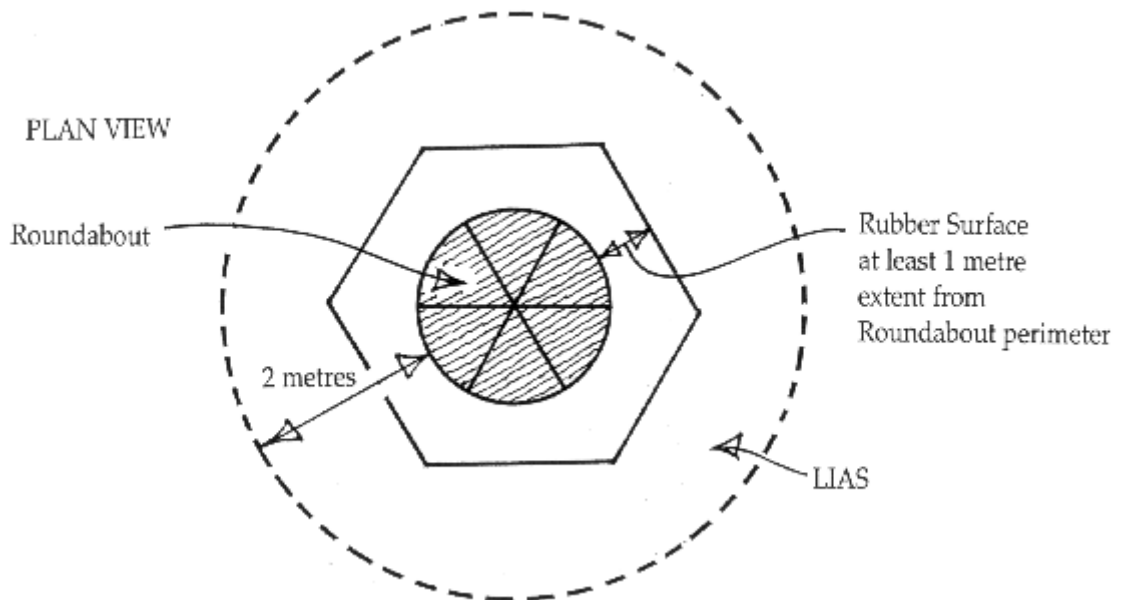

Note:

If the roundabout is more than 0.50 metres in diameter, the LIAS must extend 2.00 metres beyond roundabout perimeter. If the roundabout is less than 0.50 metres in diameter, the LIAS must extend 1.50 metres beyond roundabout perimeter.

If the roundabout is of a 'Dutch-Disc' type, the LIAS must extend 3.00 metres beyond disc perimeter.

The siting of rubber surfaces to be as in 'swing plan' detailed above.

Ensure that there is sufficient clearance of rubber surface on roundabout, to comply with European Standard BSEN1176.

Care should be taken to prevent LIAS from reducing the clearance under the roundabout perimeter, as per BS EN1176

Melcourt Play Range - Recommended Installation Procedure (Continued)

For installations with existing equipment, carefully consider:

- Will the correct ground clearance be maintained?
- Are the existing concrete foundations deep enough, or will the concrete be exposed?
- EN 1176, part 7 states that when using loose impact absorbing surfaces, the play equipment foundations should be 400mm below the surface, or if tapered for water shedding, 200mm below the surface, or be covered by the equipment.
- The 'basic level mark' will be put on the equipment superstructure by the equipment manufacturer.
- Will the equipment remain stable after the new pit has been constructed?

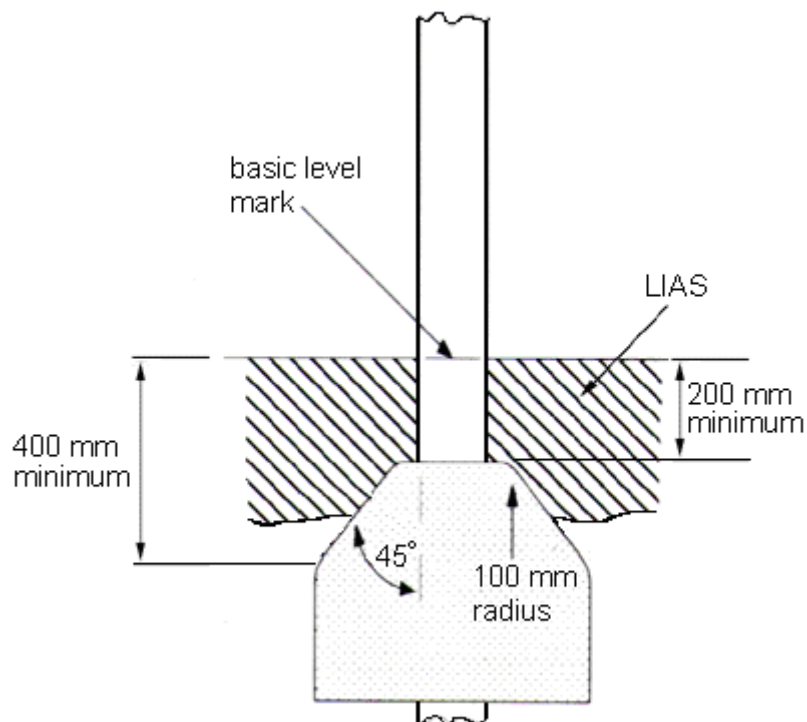



Contact

Melcourt Industries Limited, Boldridge Brake, Long Newnton, Tetbury, Gloucestershire. GL8 8RT
Tel: +44 (0)1666 502711 Fax: +44 (0)1666 504398 Email: mail@melcourt.co.uk
Web Site: www.melcourt.co.uk